

## CONTENT

<b>1. Package Contents</b> .....	<b>2</b>
<b>2. Product structure</b> .....	<b>2</b>
<b>3. Technical parameters</b> .....	<b>3</b>
<b>4. Curve</b> .....	<b>4</b>
<b>5. Steps of assembling</b> .....	<b>4</b>
<b>6. The control system structure and functions</b> .....	<b>11</b>
<b>7. Attentions</b> .....	<b>14</b>
<b>8. Troubleshooting</b> .....	<b>15</b>
<b>9. Daily maintains</b> .....	<b>16</b>
<b>10. Safety Precautions</b> .....	<b>16</b>
<b>11. Contact us</b> .....	<b>17</b>

### **Dear Owner,**

Congratulations! You have just purchased the most technologically advanced small-sized wind turbine system in the world—Hummer wind turbine.

We appreciate your purchase, and are proud of providing the excellent product to you.

Before going any further, please completely read the owner's manual, although it is easy to install your wind turbine by yourself.

We have made great efforts to satisfy your requirements in the aspects of design, manufacture, operation, applicability, etc.

Please keep the manual carefully for further reference.

If you have any questions or comments, we would like to hear from you.

Again, thanks for your purchase and wish you enjoy the convenience that Hummer Wind turbine brings to you.

**Thanks for using Hummer wind turbine----high quality and original technology**

## 1. Package Contents

Before you begin, inspect the contents to make sure there is no damage or missing parts.

Your Hummer wind turbine is shipped in 3 boxes:

Labels on outside packing box	Name of the box	Size of outer packing box	Bill of materials
500W-1	Generator box	1815×270×265mm	generator, yaw shaft with cable(1*19m), tail pole(1),pedestal(1),rotor blades(3), specification(1),a set of wire rope(Φ8mm, 4* 7.2m, 4*0.8m), accessory box [turnbuckle (4* Model OO ), lock catch(24), connecting line of battery(2*0.8m, 1*0.3m), the fixed bolt for tower(2, M10*25), connecting bolts of flange and tower(5, M10*40), pedestal pin(1)]
500W-2	Inverter controller box	565×445×203mm	inverter controller(1), tail wing (1)
500W-3	tower box	2130×240×220mm	Tower( 3 sections, Φ 76mm, length 2000mm) pedestal pin (1)

## 2. Product structure

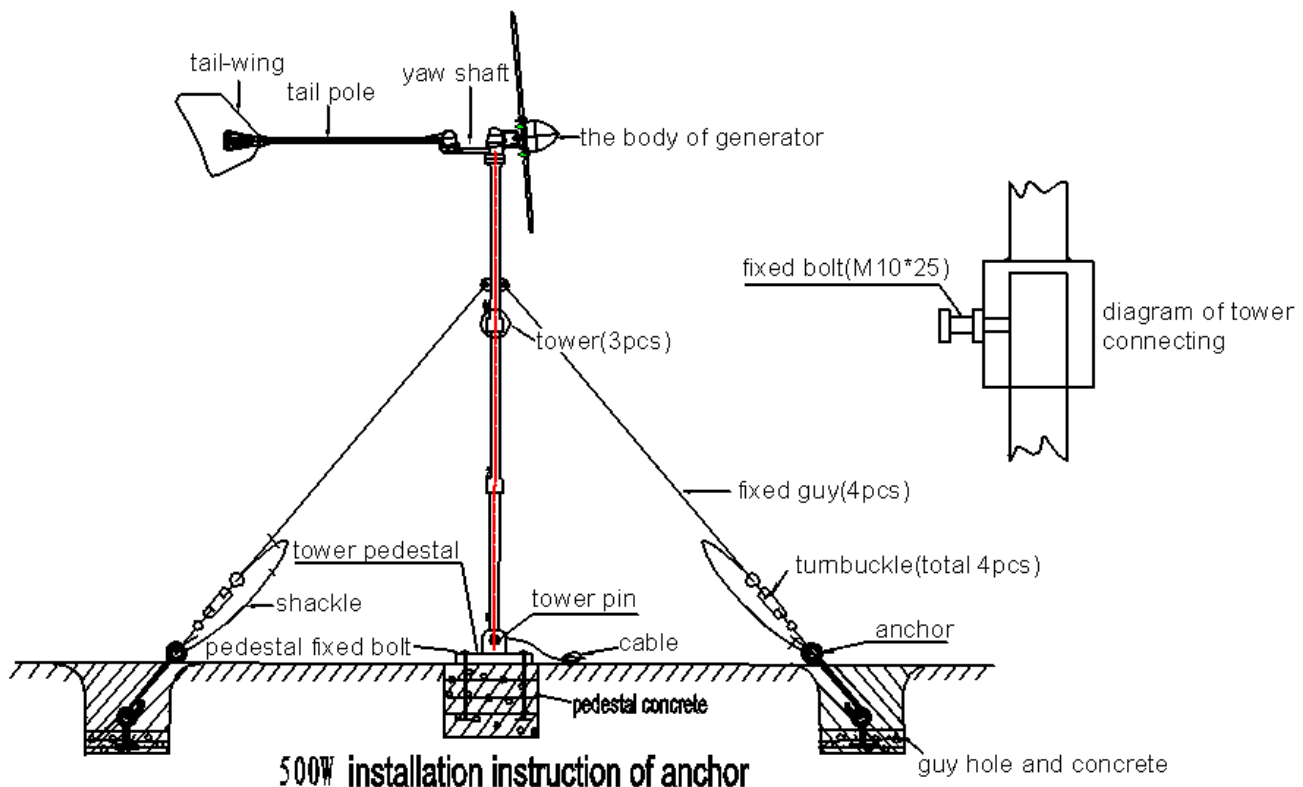

### 3. Technical parameters

Rated power(W)	500
Maximum output power (W)	1000
Charging voltage (V)	DC 24V
Blade quantity	3
Blade material	GRP(glass fiber reinforced plastic)
Blade diameter (m)	2.7
Start-up wind speed (m/s)	3
Rated wind speed (m/s)	7
Rated rotating rate (r/min)	600
Wind energy utilizing ratio (Cp)	0.48
Generator output	single-phase frequency conversion AC
Output AC frequency (Hz)	0~300
Rated charging current (A)	15
The maximum charging current (in a short time )(A)	25
Generator efficiency	>0.78
Tower diameter(mm)	Φ76*3*2000
Tower height(m)	6
Generator weight (kg)	6.5
Battery 12V 150Ah/200Ah	2pcs

## 4. Curve

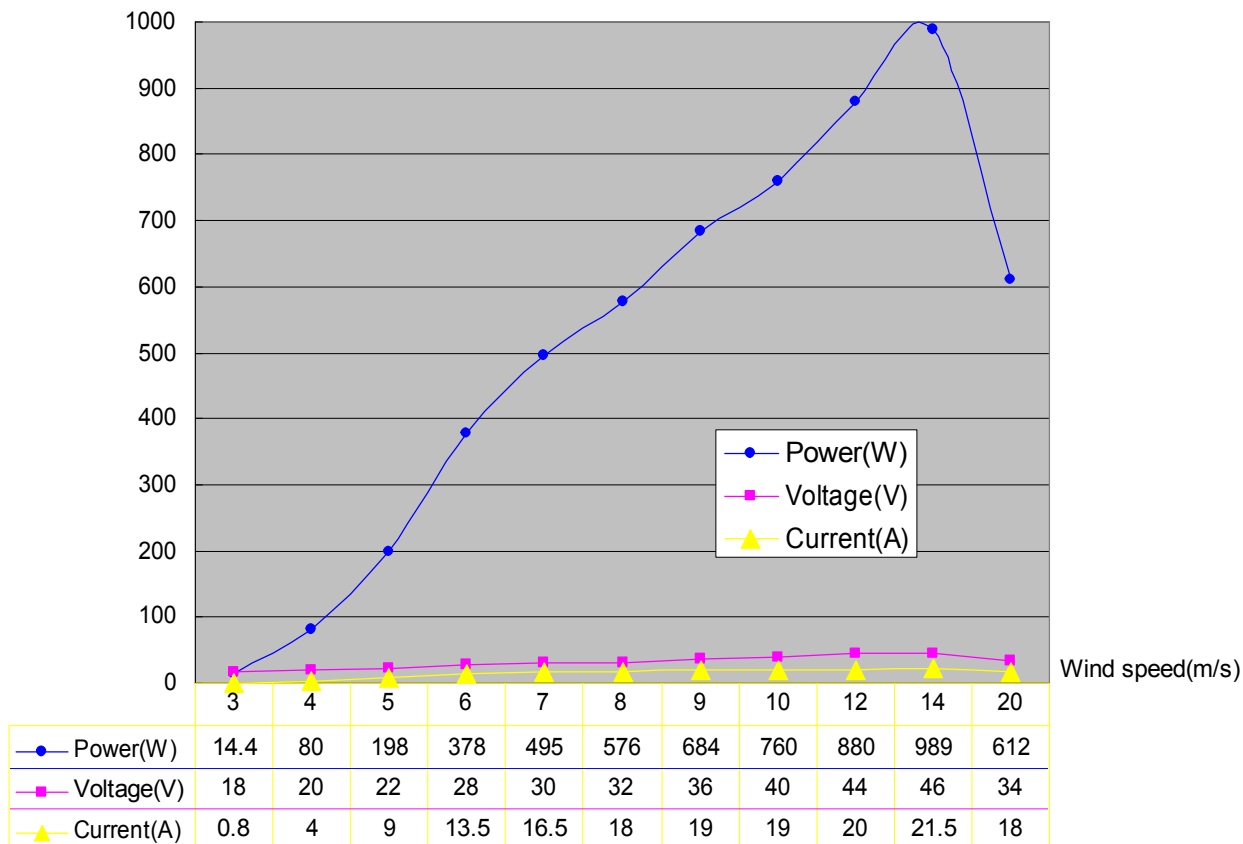

Hummer 500W Wind generator

## 5. Steps of assembling

### 5.1 Package contents

Hummer Wind Turbine -- 500W consists of 3 packing boxes.

Open the boxes and check the packing list to make sure every part is included.

Inspect the contents to make sure there is no damage or missing parts.

Any damage to the products caused by transportation be found, please contact to the locale distributor. If the products are directly sent to you by our company, please contact the shipping company, because only the consignee has right to claim.

We suggest you preserving the package in case to use for future transportation.

### 5.2 Choosing the site

The wind turbine should be erected high and far away from obstacles as possible in order to get relatively high wind speed. Meanwhile soil quality of installation location should be taken into consideration. Loose sands, uneven or easily influenced by weather condition areas should be excluded from installing the wind turbine. When selecting the locations, it's necessary to consider the distance between generator and accumulator. The shorter the distance is, the less cable would be used. As a result, less energy consumption would be produced during the transmission. While under the circumstances of longer distance, it's better to use much thicker standard cable for the transmission.

### 5.3 Pre-making pedestal and digging hole

#### ① Pre-making the tower pedestal

Pre-make one tower pedestal and four guy pedestals by concrete (C25).

Size of guy pedestal: 350\*350\*200 mm.

Size of the concrete of tower pedestal: 300\*300\*200mm.

Size of tower pedestal: 202\*202\*8mm.

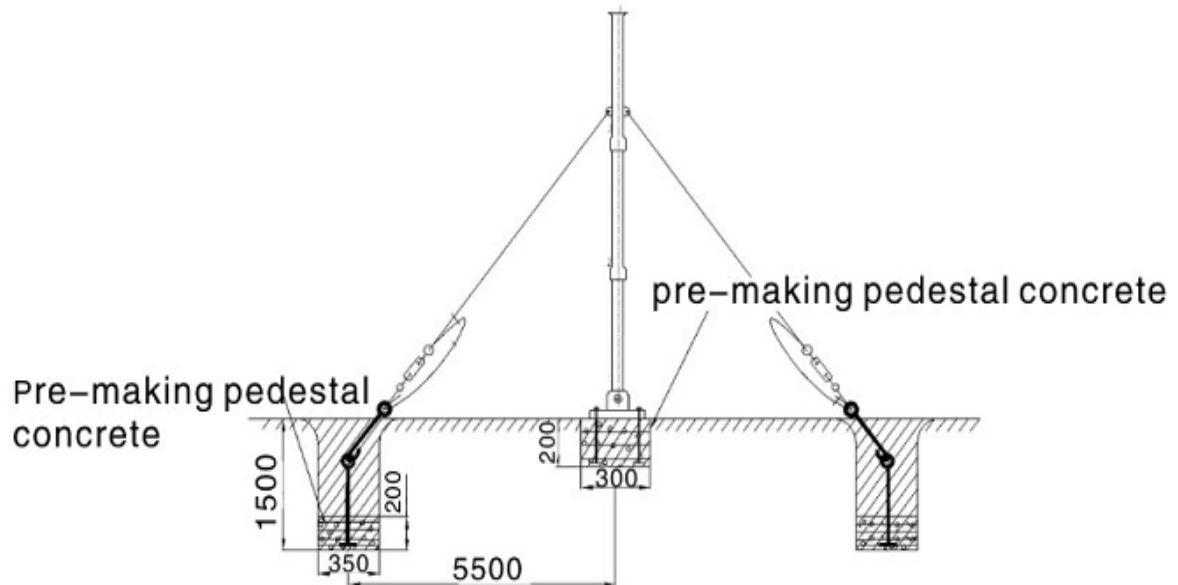

500W guy hole and pre-making pedestal concrete diagram

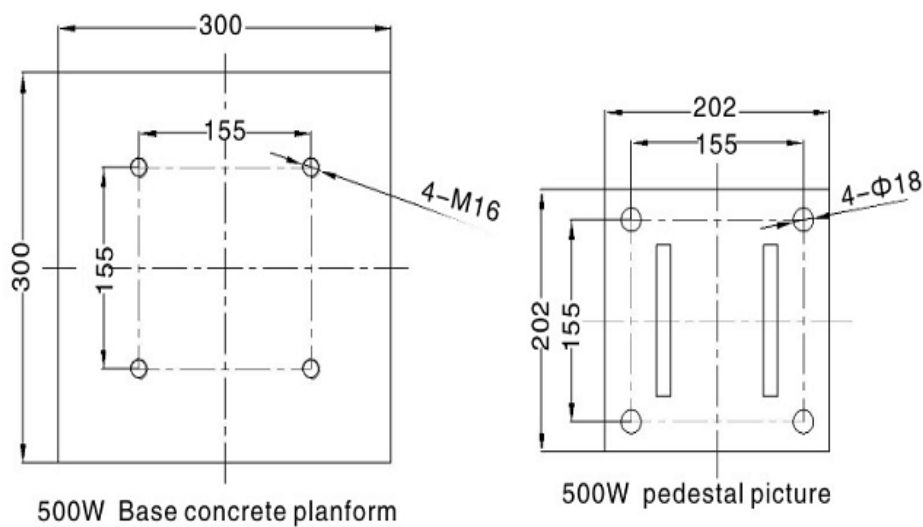

**ATTENTION:** the fixed loop on guy pedestal and the connecting rod shall be made of stainless steel. Ordinary steel can be used only after special anticorrosion treatment, such as Hot Galvanizing.

#### ② Digging the hole

Dig the hole refer to the given size, then put the tower pedestal & guy pedestals inside the hole, at last level up the ground. The guy fixed loop must be outside of the guy hole.

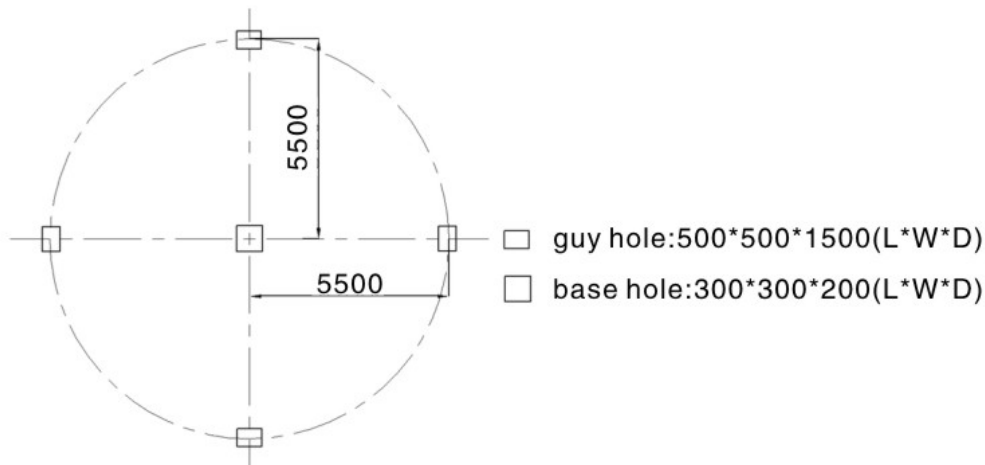

The center distance between guy hole and base hole:5500mm

#### 5.4 Connection of blades, yaw shaft, tail pole and tail wing

##### ① Assembling of blades

- a. Take out the generator, then remove the six nuts and bolts on the flange, and last take off the blade press plate to install blades.
- b. Connect the 3 blades properly to the flange screw, and then cover the blade press plate, and last pinch the nuts. Blades need exact position; as a result bolts and holes that punched on blades connect tightly, please hit the bolts in the corresponding hole.

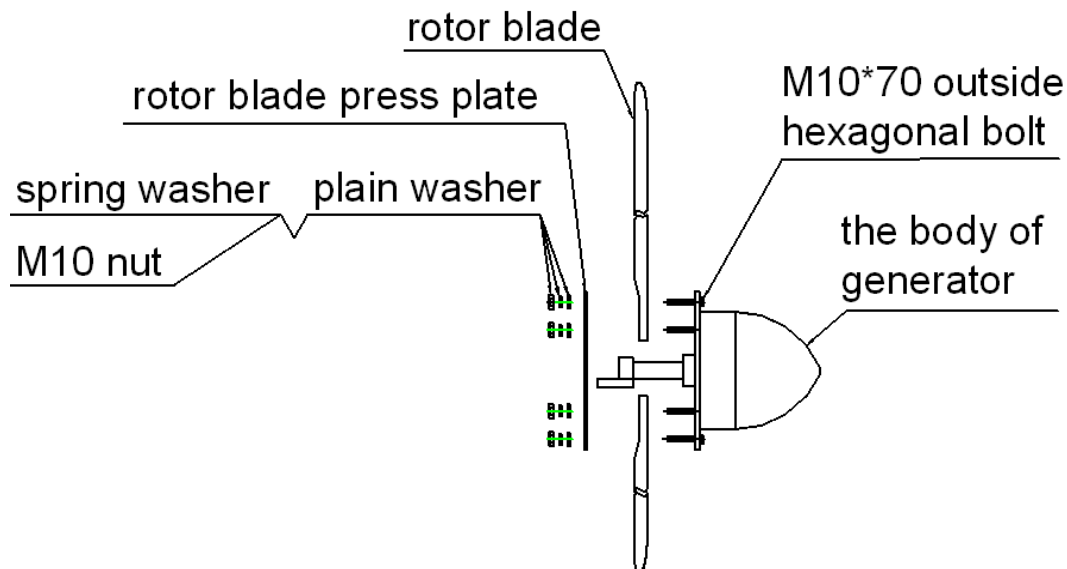

500W rotor blades installation diagram

#### ATTENTION:

- ◇ The side which marked with “front” shall be adown, and windward.
- ◇ All the 3 rotor blades have passed the balance test, it needs to use together. Please don't disorderly use the rotor blades belonging to the other generators.

- ② Connecting of tail pole, yaw shaft, and tail wing
- a. Connect tail pole to yaw shaft.
  - b. Connect tail pole and tail wing.

Firstly, connect the tail pole and yaw shaft as follows. Secondly, insert the tail wing into the tail pole. Thirdly, install the tail wing press block, and last fasten the bolt.

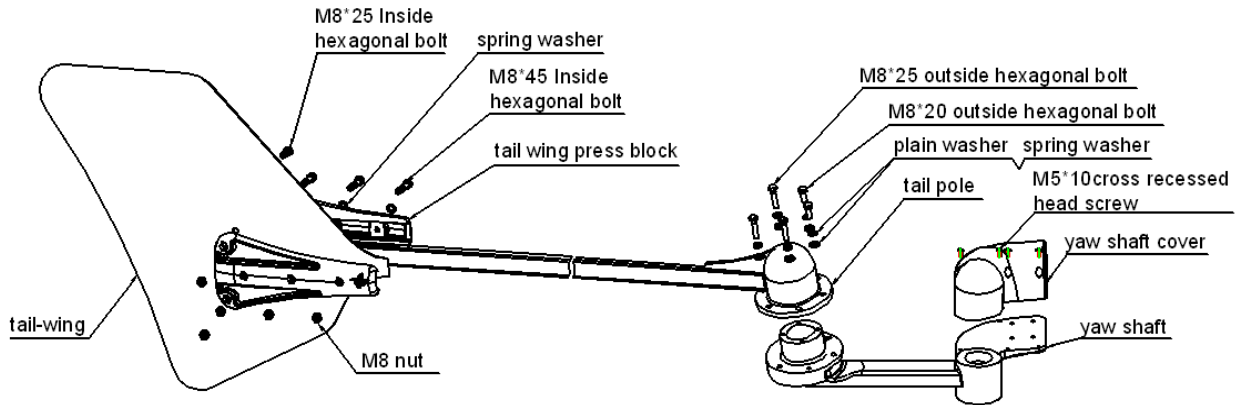

500W tail pole installation diagram

## 5.5 Connection of tower and connection of yaw shaft and tower

- ① Connecting the tower

Connect the tower from bottom up 1→2→3. Connect the first tower to the pedestal by pedestal pin and fasten the nut and bolt at the connecting point.

**ATTENTION: Directions of 4 lugs on the third section for guys are corresponded with the guy holes.**

- ② Pulling-in cable

Place the upper part of tower on the supporting stand with height about 1.2m-1.5m, pull the cable under the yaw shaft through the tower pipe with iron wire.

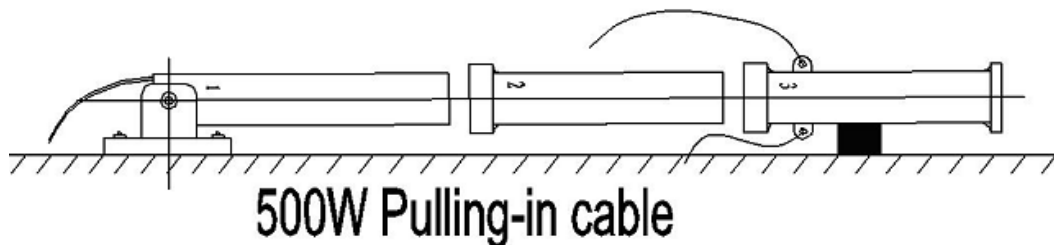

**ATTENTION:** Uplift the tower to adjust the length of 4pcs guys, and then lay tower down.

- ③ Connection of tower and yaw shaft

Connect the yaw shaft, tail pole and tail-wing to tower.

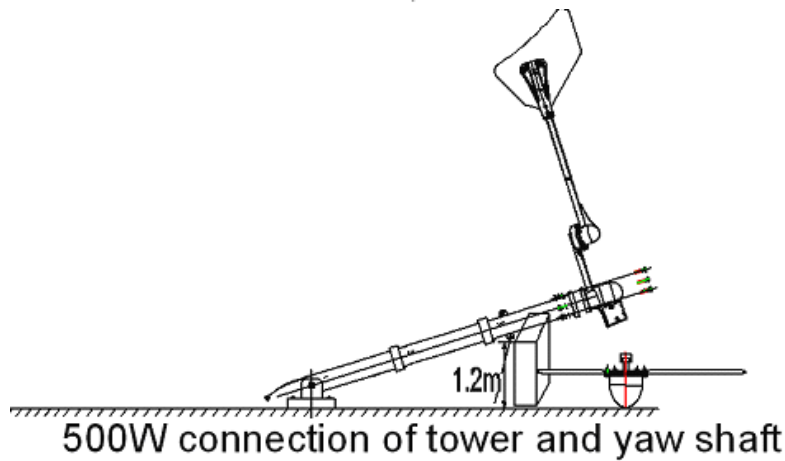
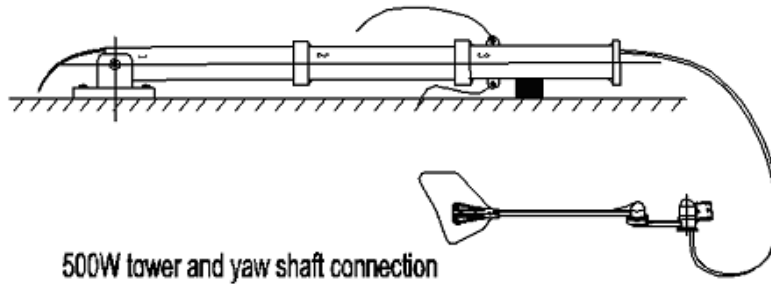

④ Connection of yaw shaft and generator

Connect the generator with blades to yaw shaft.

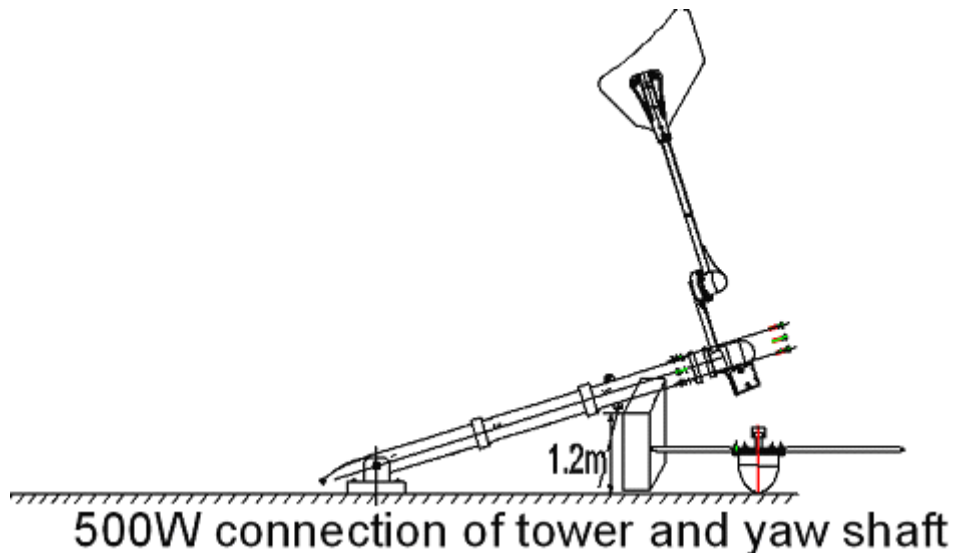

## 5.6 Erecting the wind turbine

① Connect the 4 guys to tower properly, and then connect the guy under the tower and other two guys on both sides to guy pedestals, and then fit the safety twist lock to prevent turnbuckle looseness.

**ATTENTION:** It is very important to fix the guy under the tower for avoiding the tower fall to the opposite side in the process of erecting up. Make sure the guys on both sides are tighten and

fixed to avoid the tower shaking when erecting up.

② Pull the unfixed guy by one or two people, simultaneously another two people lift the tower gradually, and then connect the guy to guy ring and fit twist lock. Adjust the guy step by step to assure that the tower is absolutely perpendicular to the ground.

**ATTENTION:**

- a. Make sure two people are holding the tower when adjusting the guy to avoid tower falling.
- b. Make sure the two cables are short circuit and connected together to avoid blades rotation during the process of erecting up.
- c. Make sure every connection point of guy and guy ring is fitted with twist lock to avoid turnbuckle looseness during adjusting.
- d. Safety shall be first concern in the process of erection and adjusting, be careful of tower falling.

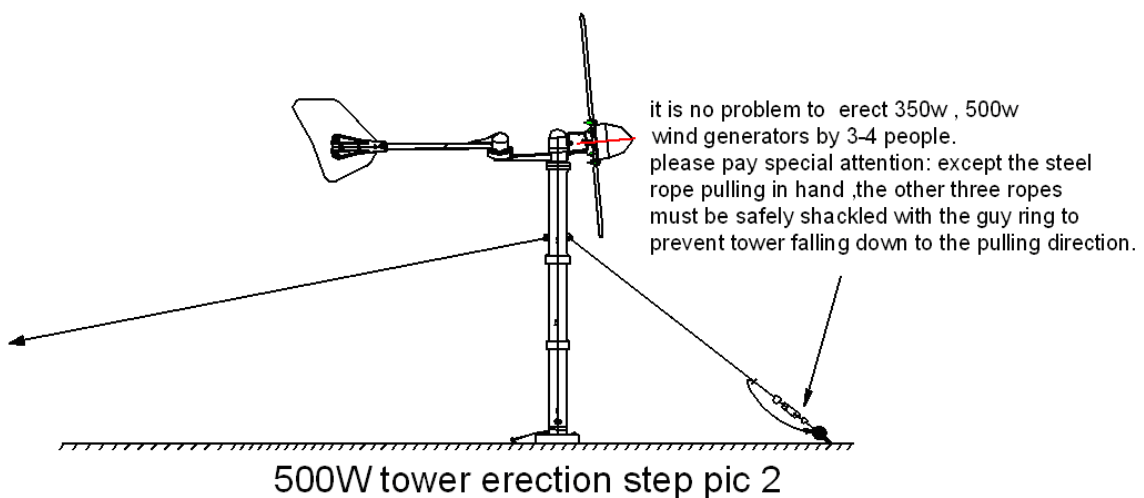
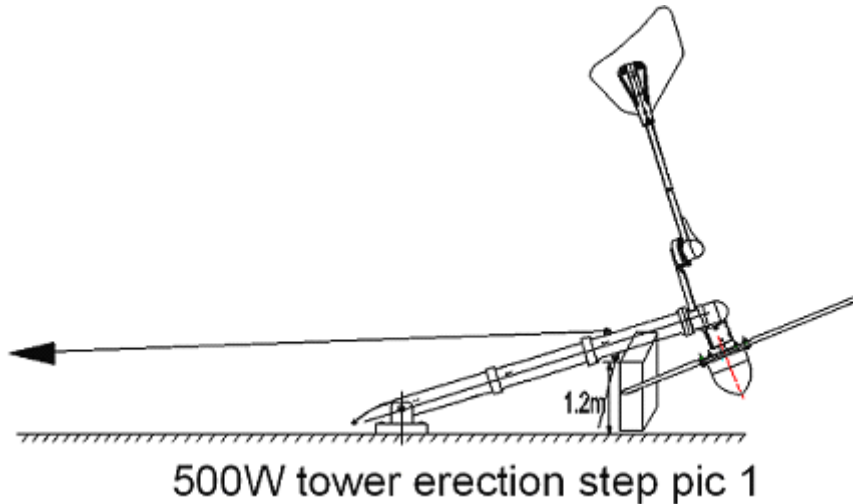

### 5.7 Connection of generator and control system

① Connection of battery and inverter controller

Hummer 500W wind turbine collocates 2pcs 12VDC batteries in series. Open the protection cover at the rear of inverter; connect the battery and the control system.

**ATTENTION:** connect the battery's anode to (+) on the inverter, connect the battery's cathode connects to (-) on the inverter, and then check if there is AC output.

② Connection of generator's cables and control system

Take off the cables of wind Generator from short circuit connecting base, and then connect them to the control system. The wind generator will run and charge the batteries if it is windy.

**ATTENTION: There is no polarity difference when connecting the generator's cables to the control system.**

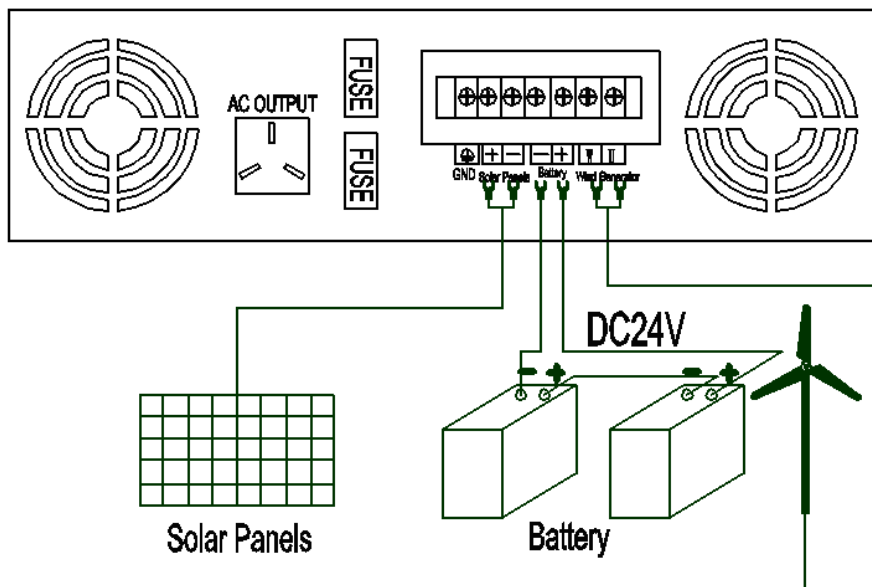

500W wind generator circuit diagram

## 5.8 Distance between two wind turbines

9m-10m is the ideal distance between 500W wind turbines.

## 5.9 Points for attention during assembly

- ① Choose calm weather (wind speed  $\leq 10$ /s) to install Hummer wind turbine. Before erecting the wind turbine, check the short circuit connecting base to assure the two cables are short circuit absolutely and the blades will not rotate.
- ② Make sure the tower is perpendicular to the ground, or the blade will not work optimally especially in low wind.
- ③ Please evaluate the guys' length before erecting the tower. Every connection point of turnbuckle is fitted with twist lock to prevent tower falling if the turnbuckle looseness.
- ④ The rotor blade is made up with 3 blades which are balanced strictly; please don't mix the

blades from two different generators disorderly; otherwise the rotor blade will run abnormally which will result in serious shaking.

⑤ The power generated by off-grid wind turbine will charge batteries after rectified, different wind turbine collocates different numbers of batteries, please strictly follow the owner's manual to choose the right number, if batteries' voltage is too high or too low the generator system may work improperly or some parts of the system could burn out.

⑥ Emergency shut-down

Please manually switch off the wind generator before typhoon or gale coming. Set the switch to the "STOP" position, the wind turbine will stop due to short circuit. Set the switch to "OPERATION" position after wind, the wind turbine will resume to work.

**ATTENTION: the manual stop switch can only be used with low wind speed or wind turbine is not working.**

## 6. The control system structure and functions

- ① Rectify AC to DC to charge the batteries.
- ② Invert DC to single-phase sine wave AC to supply users.
- ③ The controller will deliver the power to diversion lights if the battery has been fully charged.

### 6.1 Upper panel

There is a manual stop button on the upper panel of inverter. When switch the button to "work" position, generator and storage battery connect and the system works in normal condition. When switch to "stop" position, generator stops running as the two output cables are short together. When typhoon approaches, please switch the button to "stop" position to make generator stop working.

Tips: You can just switch the button from "work" to "stop" only when the rotor blades running slowly. If not, this action will cause great impact on generator.

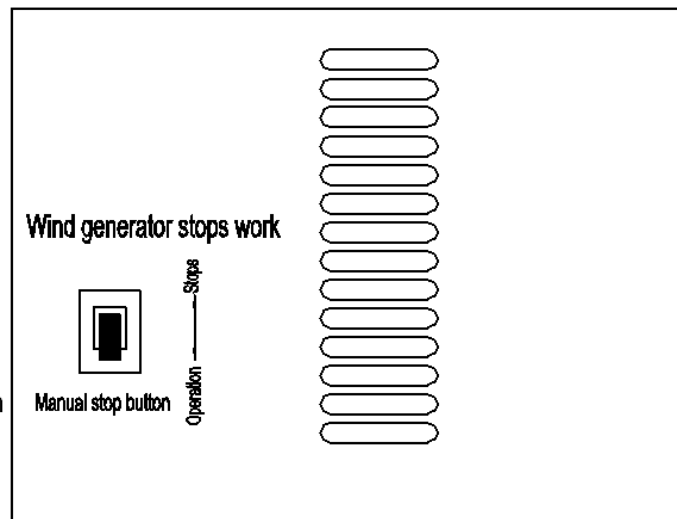

500W Inverter Upper panel

**ATTENTION: the manual stop switch can only be used with low wind speed or wind turbine is not working.**

## 6.2 Front panel

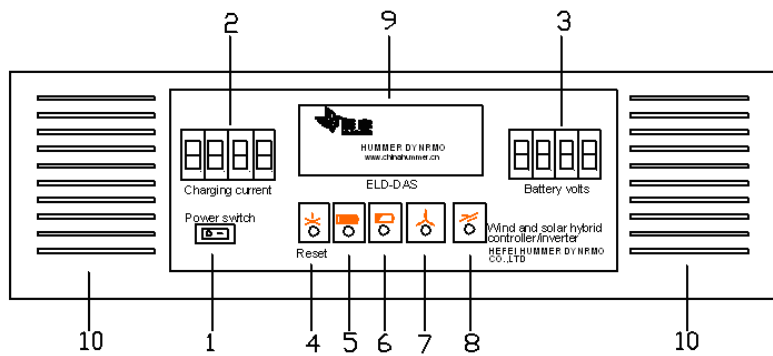

- |                                  |  |                           |
|----------------------------------|--|---------------------------|
| 1.inverter output switch         | 2.ammeter                                | 3.voltmeter               |
| 4.abnormal indicator             | 5.over charge indicator                  | 6.overdischarge indicator |
| 7.wind turbine working indicator | 8.inverter working indicator             | 9.hummer brand            |
| 10.fan                           | <b>500w inverter front panel picture</b> |                           |

- ① Inverter output switch: Turn on/off the inverter. Pure sine wave AC will be output after inverting.
- ② Ammeter: Display charging current.
- ③ Voltmeter: Display battery voltage
- ④ Abnormal indicator: Total power consumption in excess of the rated one
- ⑤ Overcharge indicator: When the charge voltage rises up to the protection voltage (15V/pcs), the wind turbine stops generating power to protect the system. When the battery voltage drop to the recovery voltage (13.5V/pcs), the wind turbine resumes rotating and begins normal charging of the battery.
- ⑥ Over discharge indicator: When the voltage drop to the protection voltage (10.5 V/pcs), the inverter will stop work, the over discharging indicator light will light up. When the battery voltage rises up to the recovery voltage (11.5V/pcs), the inverter resumes working after restarted.
- ⑦ charge indicator: When the generator and solar panel are charging batteries, the charge indicator lights up
- ⑧ Inverter working indicator: This indicator will light up when the inverter is working, and it will stop working when the battery is over discharging, overloading, or short circuit. Restart the inverter after 5 seconds the inverter will resume to work, if not; please check whether the problems have been settled. The inverter will stop working automatically in the overheating condition, and it will recover when the temperature lower down.
- ⑨ Hummer brand
- ⑩ Fan

### 6.3 Rear panel

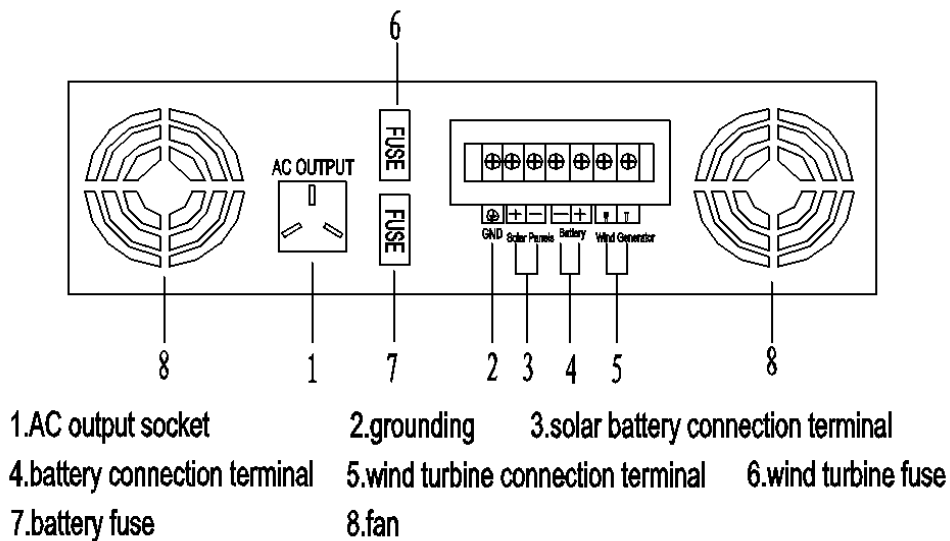

500W inverter rear panel picture

- ① AC output socket
- ② Grounding
- ③ Solar battery connection terminal
- ④ Battery connection terminal
- ⑤ Wind turbine connection terminal
- ⑥ Wind turbine fuse, fuse Parameter: 500V, 30A.
- ⑦ Battery fuse, fuse Parameter: 500V, 30A
- ⑧ Fan

### 7. Attentions

#### 1. Battery connection

The wind turbine-500W is matched with 2pcs batteries (12V120AH-200AH). Firstly, connect the 2pcs in series. Secondly, connect batteries to controller. The battery has anode and cathode, connect the red to anode (+), the back to cathode (-).

**NOTE: please charge the new batteries with city grid prior to using.**

#### 2. Connect solar panel

The controlling equipment of Hummer-500W can connect solar panel (250w) simultaneously. Please contact our company or the local dealer for details.

The solar panel has anode and cathode, connect the red wire to anode (+), the back wire to cathode (-).

#### 3. Turn on the inverter switch before using load.

4. Pay attention to the fuse Parameters: fuse parameters of both battery and generator are 500V, 30A.

5. To protect wind turbine, please manually set the controller switch to stop before severe typhoon coming.

#### 6. Attention

Do not let the controller affected with rain & damp to decrease the dangers of fire and electric shock. Please use the controller in a well ventilated place, which will be helpful to output the heat.

★ Do not put the controller on textiles such as bed, sofa, and cloth for the better airing.

#### ★ Sweeping

Please turn off the inverter before sweeping, do not use any water, soft cloth will be the perfect choice.

#### ★ Heat producer

Put the controller far away from heat producers, such as heater, heat regulator, heating furnace and any other heating products.

#### ★ Wire

The supply line should be located at the place which can't be stamped, and also can't be pressed by other things. Additionally, the plug, socket, and supply line all need special protection.

#### ★ Overload

All the overload actions will lead to fire or electric shock.

#### ★ Stuff

Do not put anything inside the machine or it will cause short circuit, fire and electric shock.

#### ★ Moisture

Any kind of liquid should be put far away from the machine.

#### ★ Repair

Any kind of repair of the owner is forbidden; please contact the authorized technicians for help.

## 8. Troubleshooting

<b>problems</b>	<b>possible cause</b>	<b>solution</b>
Inverter indicator lights up without outputting AC voltage	1. The outlet and plug are not fixed enough. 2. The fuse has blown	1. Fix the outlet and plug. 2. Change the fuse.
Inverter indicator not lights up & without AC voltage	1. If the over discharging indicator is lighting that maybe the battery is under voltage. 2. If the over discharging indicator is lighting that maybe because of overload.	1. Charge the battery 2. reduce the load

Generator is running but without AC display and can't charging	<ol style="list-style-type: none"> <li>1. The wind speed is too low to reach the requirements of voltage</li> <li>2. The fuse has blown.</li> </ol>	<ol style="list-style-type: none"> <li>1. Need a normal wind speed, which can help to reach the required charging voltage.</li> <li>2. Change the fuse</li> </ol>
Abnormal indicator is lighting, buzz, can be reset	<ol style="list-style-type: none"> <li>1. The wind is too strong</li> <li>2. The load is too heavy</li> </ol>	<ol style="list-style-type: none"> <li>1. Manually stop the machine</li> <li>2. Lighten the load</li> </ol>
Both the overcharging indicator and unload indicator are not light	<ol style="list-style-type: none"> <li>1. The wind is not strong enough</li> <li>2. The unload indicator is broken</li> </ol>	<ol style="list-style-type: none"> <li>1. Make sure the wind speed</li> <li>2. Change the unload indicator</li> </ol>
The blades rotate unsteady	Blades out of balance	Check if the blade assembled disorderly, or change another set of blades
The rotor blades move slowly with enough wind	<ol style="list-style-type: none"> <li>1. Short circuit of wirings</li> <li>2. The generator is burnt down</li> </ol>	<ol style="list-style-type: none"> <li>1. Check whether the wire has short circuited</li> <li>2. Change another generator</li> </ol>
Rotor blades rotate faster than usually	Generator loses load	Check if the output line and the fuse are broken, and then reconnect the load

## 9. Daily maintains

The Hummer wind turbine is highly reliable and does not need regular maintenance. However, the overall system of wind turbine must be inspected and maintained regularly to ensure the system's normal operation.

### 9.1 Guy inspection

Check the tower guys for loosening and fasten any loosened wiring in a timely manner. Carry out this inspection multiple times in the initial three months after tower erection. It is also necessary to check wiring after gales.

### 9.2 Screw inspection

Check the screws on flange, yaw shaft and tower, and then fasten them, at least twice every year.

### 9.3 Transmission line inspection

Check to see if various connecting points of the wires are well-connected or are corroded.

### 9.4 Battery Maintenance

Regularly check and maintain the battery bank as per the maintenance requirements of the batteries.

## 9.5 TIPS

Do not stand near the turbine during gale weather.

It is recommended that you lay down the tower or bid blades with tower in the case of approaching extremely rough weather (such as typhoons or hurricanes) to avoid accidents.

## 10. Safety Precautions

The Hummer wind generator is designed under strict safety regulations. However, any electrical and/or mechanical equipment during installation or operation can cause potential inherent dangers, if the proper safety precautions are not taken. Please read the following safety precautions thoroughly before you choose the turbine location, plan to install or operate the turbine.

### 10.1 Mechanical hazards

Rotating blades can move fast enough that the tip of a blade is almost invisible, which can cause serious injury or damage to anything it contacts. Do not install the turbine where anyone can come in contact with the blades.

### 10.2 Electrical hazards

- ◆ The product is equipped with needed protection device to avoid electrical dangers. Don't forget that the potential dangers still exist in wind turbine, so please be careful during the process of connecting wires and other electronic equipment.
- ◆ Undersized wire or a bad connection can cause over-current electrical dangers and overheating in wiring systems that could cause fire or other personal dangers. Thus it is important to check the wire connections in daily times.
- ◆ Please strictly follow the manual when you operate the controller.
- ◆ Fire will be caused by the short circuit of batteries. In order to avoid this threat, you should make sure the fuse in a good condition.

### 10.3 Assembling hazards

Please follow the basic condition during your assembling:

- Safety first
- Choose calm weather
- Stand on the ground when you install the system.
- Have someone available to help
- Make sure that the rotor blade not are rotating when you link the battery wire.
- After the connection of generator and tower, you can fix the rotor blades. Please lay the tower down on the ground before fixing the blades.

#### **10.4 NOTICES:**

This information is believed to be correct and reliable. However, Hummer Company assures no responsibility for inaccuracies or omissions. The owner of this information and product assumes full responsibility and risk owing to improper usage or improper comprehension.

**Hummer Company has the final power to interpret this manual.**

#### **11. Contact us**

You can contact us with the following methods; tell us the problems you met in the process of using the wind turbine. We will supply you the technology support and after service, thanks again for your purchase.

All specifications are subject to change without notice.

Add: Room 2904, Building No.5, Jindi international City, No. 88 South of Ma'anshan Road, Hefei, Anhui, P. R. China

TEL for sale: +86-551-3441230

+86-551-3444231

FAX for sale: +86-551-3442991

E-mail: [hummerpower@163.com](mailto:hummerpower@163.com)

Website: <http://www.chinahummer.cn/eng/>